



BRAVO² Series

BV-200R Motion Detector

INSTALLATION INSTRUCTIONS

FEATURES

- **Multi-Level Signal Processing***
- **Dual element low noise sensor**
- **Four interchangeable lenses**
- **High level static protection**
- **High level transient protection**
- **High level white light immunity**
- **Excellent RF immunity**
- **Temperature compensation**
- **Fast / slow detection jumper**
- **LED on / off jumper**
- **Vertical adjustment**
- **SMD construction**
- **Super quiet operation**
- **Wall / corner mounting**
- **Small size**
- **Blends with any decor**
- **5 YEAR WARRANTY**

INTRODUCTION

The Bravo 2 is a general purpose PIR designed to provide reliable motion detection for residential and commercial applications.

Exceptional design care and factory testing ensure years of trouble free performance. Immunity against false alarms from RF, static, electrical transient and white light are all designed in features.

Multi-Level Signal Processing*, temperature compensation and large multi-beam lens design means the human target will not slip by unnoticed even on a hot summer day.

Four interchangeable lenses, wall or corner mounting and vertical adjustment provide application versatility, and your client will appreciate the small size and elegant simplicity of the case design.

Our Bravo 2 with its 5 year warranty is your assurance of a trouble free installation.

* Protected by one or more of the following patents:
Canada 2099971, US 5444432

SPECIFICATIONS

Operating voltage	9.5V _{DC} -14.5V _{DC}
Supply voltage ripple	3.0V pp @ 12V _{DC}
Standby current	less than 16mA
Current in alarm	less than 20mA
Contact rating (alarm & tamper)	100mA @ 24V _{DC}
Alarm contact resistor in common	10 ohm 1/4W
Operating temperature :	0°C to 50°C
Storage temperature :	-40°C to 60°C
Operating humidity	5% to 95% RH non-cond.
Storage humidity	up to 99% RH non cond.
RF immunity	50 V/m over range 0.01MHz-1.2GHz
Static immunity	25kV
Transient immunity	2.4kV @ 1.2 joules
White light immunity	20,000 Lux at the detector
Walk detection speed	0.15m-3.0m/s
Coverage angle (wall/wall lens)	90° minimum
Vertical adjustment	+5° to -10°
Mounting heights	2m to 3.0m (nominal 2.3m) 1.2m to 1.5m (pet alley only)

COVERAGE

Wall-to-Wall lens (BV-L1)	13m × 13m
Corridor lens (BV-L2)	22m × 2m
Curtain lens (BV-L3)	13m × 1m
Pet Alley lens (BV-L4)	13m × 13m

PHYSICAL

Dimensions: 89 mm × 64 mm × 48 mm

Colour: White case with light gray lens

Shipping Weight: 190 g

Models: BV-200R Form A alarm contact & tamper switch

MOUNTING HEIGHT CHART

HEIGHT m	SETTING FOR FULL RANGE			
	WALL/WALL	CORRIDOR	CURTAIN	PET ALLEY
3 m	0.00	-0.25	0.00	=====
2.4 m	+0.50	+0.25	0.00	=====
2.1 m	+0.75	+0.25	0.00	=====
1.8 m	+1.00	+0.50	0.00	=====
1.5 m	=====	=====	=====	0.00
1.2 m	=====	=====	=====	0.00

WALL-TO-WALL LENS

TOP VIEW

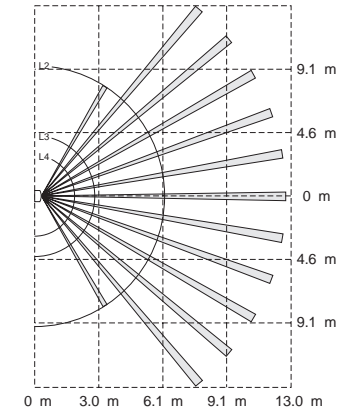

SIDE VIEW

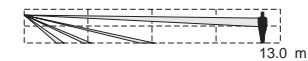

CORRIDOR LENS

TOP VIEW

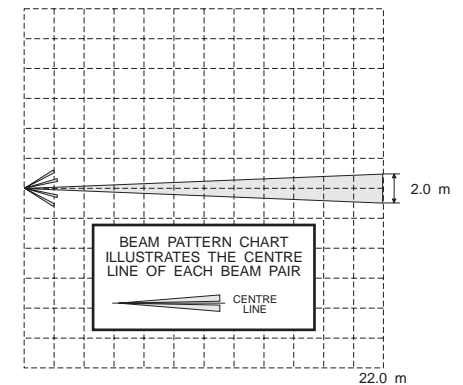

SIDE VIEW

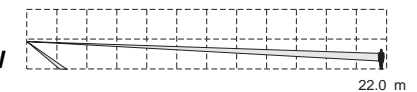

CURTAIN LENS

SIDE VIEW

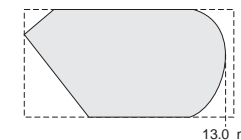

TOP VIEW

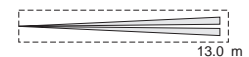

LOCATING THE DETECTOR

Select a detector location that will provide the coverage required keeping in mind the following potential problems:

Reflective Surfaces: Do not aim the detector at reflective surfaces such as mirrors or windows as this may distort the coverage pattern or reflect sunlight directly onto the detector.

Air Flow: Avoid locations that are subject to direct high air flow such as near an air duct outlet.

Moisture: Do not locate the detector near sources of steam or oil.

The Sun: Do not aim the detector such that it will receive direct or reflected (mirror) sunlight,

Pets: If there are pets on the premises, use the pet alley lens.

Obstructions: Do not limit the coverage by large objects within the detection area such as plants or filing cabinets.

MOUNTING

To open the case, use a small flat blade screwdriver and gently push in the tab at the bottom of the case and pull the cover straight out at the bottom. Loosen the PCB screw, and push the board up as far as it will go. Using a small screwdriver, remove the appropriate knockouts for the mounting screws. Remove the left and/or right wiring entrance knockouts located at the top of the backplate. Mount the backplate using the screws supplied.

VERTICAL ADJUSTMENT

NOTE: Range and dead zones may vary due to settings.

Using the Mounting Height Chart, set the vertical adjustment to get the desired coverage. Ensure that the PCB retaining screw is tightened just enough to prevent board movement.

Moving the circuit board DOWN will **increase** the far range and move the near beams farther out from the mounting wall. Moving the circuit board UP will **reduce** the far range and bring the near beams closer to the mounting wall. Moving the circuit board DOWN too far will cause the far beams to "look" above the target as a result, the range may appear shorter.

JUMPER J1 will enable/disable the alarm LED. If J1 is OFF, the LED will not operate on alarm. If J1 is ON the LED will operate on alarm.

JUMPER J2 selects between "FAST" and "SLOW" operation. For a typical environment, the unit should be set on "FAST" (J2 ON). If the environment presents potential disturbances that cannot be avoided, set J2 to OFF for "SLOW" operation.

NOTE: The corridor lens should not be used in a corridor that is less than 1.8 m. Ensure the beams are aimed directly down the centre of corridor. With the corridor lens, set J2 to "FAST".

CHANGING LENSES

The Bravo 2 is supplied with the "wall-to-wall" lens. To change the lens, release the top tab and pull the lens holder out. This action releases the lens. Insert the lens with the GROOVES FACING INWARD. The bottom of the lens is indicated by two triangular indentations. Ensure that the lens is centred left to right then reinstall the lens holder. The lens holder will snap into place sealing the lens into position.

WIRING

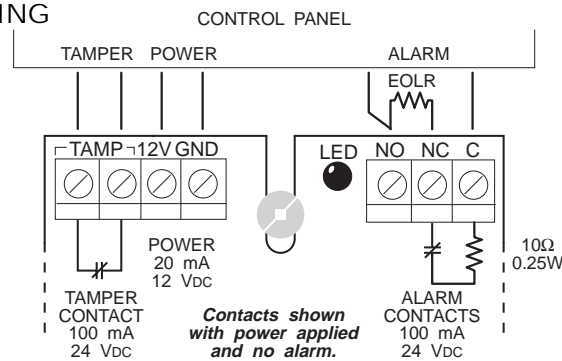

WALK TESTING

Once the detector has been set up, walk test the entire area where coverage is desired. Should the coverage be incomplete, readjust or relocate the detector to obtain full coverage. Once coverage is as required, the alarm LED may be disabled by setting J1 to OFF.

IMPORTANT NOTE: Upon installation, the unit should be thoroughly tested to verify proper operation. The end user should be instructed on how to perform walk tests, and should walk test the detector regularly.

DM-C and DM-W Detector Mounting Brackets

Use the optional DM-W Wall Mount and DM-C Ceiling Mount brackets to solve difficult placement problems. The DM-W and DM-C mount to the wall or ceiling and allow full vertical and horizontal positioning of the motion detector; the detector can be tilted up or down and rotated through 90° to obtain the best position for optimal coverage. The Bravo has been designed to be fully compatible with the DM-W and DM-C brackets. Contact your DSC distributor for more information.

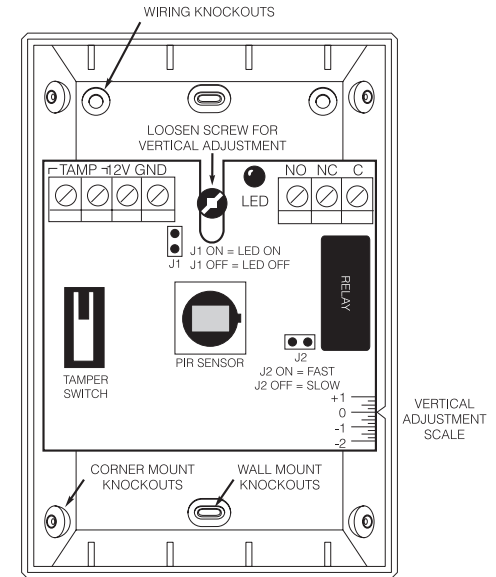

Limited Warranty

Digital Security Controls Ltd. warrants that for a period of five years from the date of purchase, the product shall be free of defects in materials and workmanship under normal use and that in fulfillment of any breach of such warranty, Digital Security Controls Ltd. shall, at its option, repair or replace the defective equipment upon return of the equipment to its repair depot. This warranty applies only to defects in parts and workmanship and not to damage incurred in shipping or handling, or damage due to causes beyond the control of Digital Security Controls Ltd. such as lightning, excessive voltage, mechanical shock, water damage, or damage arising out of abuse, alteration or improper application of the equipment.

The foregoing warranty shall apply only to the original buyer, and is and shall be in lieu of any and all other warranties, whether expressed or implied and of all other obligations or liabilities on the part of Digital Security Controls Ltd. Digital Security Controls Ltd. neither assumes, nor authorizes any other person purporting to act on its behalf to modify or to change this warranty, nor to assume for it any other warranty or liability concerning this product.

In no event shall Digital Security Controls Ltd. be liable for any direct, indirect or consequential damages, loss of anticipated profits, loss of time or any other losses incurred by the buyer in connection with the purchase, installation or operation or failure of this product.

Motion detectors can only detect motion within the designated areas as shown in their respective installation instructions. They cannot discriminate between intruders and intended occupants. Motion detectors do not provide volumetric area protection. They have multiple beams of detection and motion can only be detected in unobstructed areas covered by these beams. They cannot detect motion which occurs behind walls, ceilings, floor, closed doors, glass partitions, glass doors or windows. Any type of tampering whether intentional or unintentional such as masking, painting, or spraying of any material on the lenses, mirrors, windows or any other part of the detection system will impair its proper operation.

Passive infrared motion detectors operate by sensing changes in temperature. However their effectiveness can be reduced when the ambient temperature rises near or above body temperature or if there are intentional or unintentional sources of heat in or near the detection area. Some of these heat sources could be heaters, radiators, stoves, barbecues, fireplaces, sunlight, steam vents, lighting and so on.

Warning: Digital Security Controls Ltd. recommends that the entire system be completely tested on a regular basis. However, despite frequent testing, and due to, but not limited to, criminal tampering or electrical disruption, it is possible for this product to fail to perform as expected.

Important Information: Changes or modifications not expressly approved by Digital Security Controls Ltd. could void the user's authority to operate this equipment.



© 1997 Digital Security Controls Ltd.
1645 Flint Road, Downsview, Ontario, Canada M3J 2J6
(416) 665-8460 Fax: (416) 665-7498